

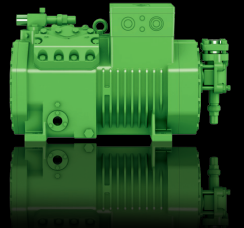

BITZER COMPRESSOR RECIPROCATING RETROFIT GUIDE

TECHNICAL INFORMATION

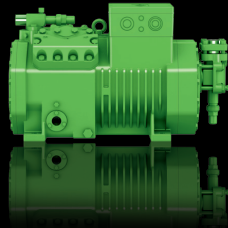
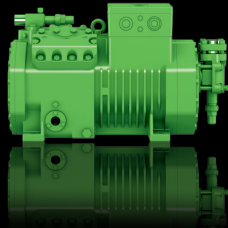
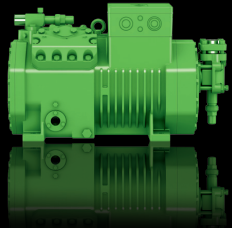

BITZER COMPRESSOR RECIPROCATING RETROFIT GUIDE



The BITZER Group is the world's largest independent manufacturer of refrigeration and air conditioning compressors with subsidiaries and production sites for reciprocating, screw, scroll compressors and pressure vessels all over the globe.

BITZER ranks among the leading manufacturers of refrigerant compressors with the highest degree of reliability and product quality. Some 3,000 employees in more than 90 countries stand behind this success, people who are dedicated to putting all of their energy into making sure that the temperature will be perfect in the future too.

The compressor is the heart of any refrigeration or air conditioning system, it must beat dependably. For over 80 years, the name BITZER has stood for worldwide leading compressor technology which gives you complete confidence in any refrigeration or air conditioning application.

The BITZER Compressor Reciprocating Retrofit Guide is an extension to our technical support. It has been created as an easy-to-use tool to compare the major compressor brands and their models to the equivalent and latest BITZER models. We are positive that you will find this guide a handy tool whether you are engineering, retrofitting an old system or replacing a compressor to the latest BITZER model.

BITZER, the heart of freshness.

1
- New valve plate design

2
- New cylinder head design -
less pulsation

3
- Optimized gas flow for
minimum pressure drop

5
- Specially adapted highly
efficient motor

4
- New piston and connecting
rod design

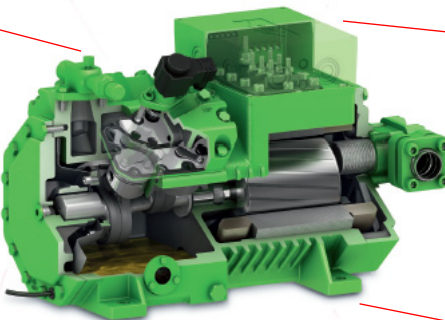

EXPLANATION OF MODEL DESIGNATION



4 N E S - 20 Y - 40P

Index for number of cylinders

(double with tandem compressor)

4 N E S - 20 Y - 40P

Identification letter for bore x stroke

4 N E S - 20 Y - 40P

Identification letter for BITZER ECOLINE series

4 N E S - 20 Y - 40P

Code for centrifugal lubrication

4 N E S - 20 Y - 40P

Code for motor size

4 N E S - 20 Y - 40P

Identification letter for ester oil charge

4 N E S - 20 Y - 40P

Motor code

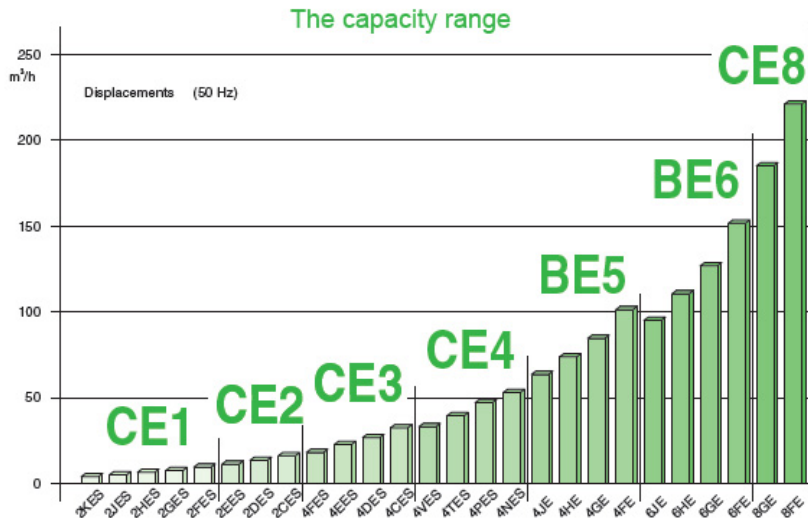

TABLE OF CONTENTS



// Page 6 - Compressor Comparison: 2KES-05Y..2HES-2Y	// Page 22 - Compressor Comparison: 4JE-13Y..4HE-25Y
// Page 7 - Technical Data: 2KES-05Y..2HES-2Y	// Page 23 - Compressor Comparison: 4GE-20Y..4GE-30Y
// Page 8 - Compressor Comparison: 2GES-2Y..2FES-3Y	// Page 24 - Compressor Comparison: 4FE-25Y..4FE-35Y
// Page 9 - Technical Data: 2GES-2Y..2FES-3Y	// Page 25 - Technical Data: 4JE-13Y..4FE-35Y
// Page 10 - Dimensional Drawings: 2KES-05Y..2FES-3Y	// Page 26 - Dimensional Drawings: 4JE-13Y..4FE-35Y
// Page 11 - Compressor Comparison: 2EES-2Y..2CES-4Y	// Page 27 - Dimensional Drawings: 4JE-13Y..4FE-35Y
// Page 12 - Technical Data: 2EES-2Y..2CES-4Y	// Page 28 - Compressor Comparison: 6JE-22Y..6GE-40Y
// Page 13 - Dimensional Drawings: 2EES-2Y..2CES-4Y	// Page 29 - Technical Data: 6JE-22Y..6GE-40Y
// Page 14 - Compressor Comparison: 4FES-3Y..4EES-6Y	// Page 30 - Dimensional Drawings: 6JE-22Y..6GE-40Y
// Page 15 - Compressor Comparison: 4DES-5Y..4CES-9Y	// Page 31 - Compressor Comparison: 6FE-40Y..6FE-50Y
// Page 16 - Technical Data: 4FES-3Y..4CES-9Y	// Page 32 - Technical Data: 6FE-40Y..6FE-50Y
// Page 17 - Dimensional Drawings: 4FES-3Y..4CES-9Y	// Page 33 - Dimensional Drawings: 6FE-40Y..6FE-50Y
// Page 18 - Compressor Comparison: 4VES-6Y..4TES-12Y	// Page 34 - Compressor Comparison: 8GE-60Y..8FE-70Y
// Page 19 - Compressor Comparison: 4PES-10Y..4NES-20Y	// Page 35 - Technical Data: 8GE-60Y..8FE-70Y
// Page 20 - Technical Data: 4VES-6Y..4NES-20Y	// Page 36 - Dimensional Drawings: 8GE-60Y..8FE-70Y
// Page 21 - Dimensional Drawings: 4VES-6Y..4NES-20Y	// Page 37 - Technical Data Explanations

BITZER COMPRESSOR COMPARISON

2KES-05Y .. 2HES-2Y



Displacement at 1450 min ⁻¹ (m ³ /h)	BITZER	BITZER Former Models	Dorin	Bock	Frascold	Copeland China	Copeland DWM
4.06	2KES-05Y	2KC-05.2	H40CC H75CC	-	A05-4Y	-	DKM-50 DKM-5X DKM-75 DKM-7X DKM-100
5.21	2JES-07Y	2JC-07.2	H100CC	HG12P/60-4 S	A05-5Y A07-5Y A07-6Y A1-6Y	-	DKJ-75 DKJ-7X DKJ-100 DKJ-10X DKJ-150 DKJ-15X
6.51	2HES-1Y 2HES-2Y	2HC-1.2 2HC-2.2	H150CC	HG12P/75-4 HG12P/75-4 S	A1-7Y A1.5-7Y	-	DKSJ-100 DKSJ-10X DKSJ-150 DKSJ-15X

TECHNICAL DATA

2KES-05Y .. 2HES-2Y



Compressor type	Motor version	Displacement at 1450 min ⁻¹ (m ³ /h)	Number of cylinders	Oil charge dm ³	Weight kg	Pipe connections				CR - Steps - % ^①	Motor connection Volt ^②	Electrical data	
						DL Discharge line		SL Suction line				Max. Operating current Amp. ^③	Max. Power consumption kW ^③
						mm	inch	mm	inch				
2KES-05Y	1	4.06	2	1.0	43	12	½	16	⅝	-	Δ / Y	4.9/2.8	1.5
2JES-07Y	1	5.21	2	1.0	43	12	½	16	⅝	-	220..240Δ/ 380..420Y/3/50	6.4/3.7	1.9
2HES-1Y	2	6.51	2	1.0	44	12	½	16	⅝	-	265..290Δ/	6.7/3.8	2.0
2HES-2Y	1				45						440..480Y/3/60	7.8/4.5	2.4

BITZER COMPRESSOR COMPARISON

2GES-2Y .. 2FES-3Y



Displacement at 1450 min ⁻¹ (m ³ /h)	BITZER	BITZER Former Models	Dorin	Bock	Frascold	Copeland China	Copeland DWM
7.58	2GES-2Y	2GC-2.2	H180CC	HG12P/90-4 HG12P/90-4 S	A1.5-8Y	-	DKL-150 DKL-15X DKL-20X
9.54	2FES-2Y 2FES-3Y	2FC-2.2 2FC-3.2	H200CC H220CC	HG12P/110-4 HG12P/110-4 S	B1.5-9.1Y B1.5-10.1Y B2-10.1Y	LA10-0200 LA10-020E	DKSL-15X DKSL-200 DKSL-20X DLE-201 DLE-20X

TECHNICAL DATA

2GES-2Y .. 2FES-3Y



Compressor type	Motor version	Displacement at 1450 min ⁻¹ (m ³ /h)	Number of cylinders	Oil charge dm ³	Weight kg	Pipe connections				CR - Steps - % ^①	Motor connection Volt ^②	Electrical data	
						DL Discharge line		SL Suction line				Max. Operating current Amp. ^③	Max. Power consumption kW ^③
						mm	inch	mm	inch				
2GES-2Y	1	7.58	2	1.0	45	12	½	16	⅝		220..240Δ/	8.7/5.0	2.7
2FES-2Y	2	9.54	2	1.0	45	12	½	16	⅝	-	380..420Y/3/50	9.2/5.3	2.9
2FES-3Y	1										265..290Δ/	10.7/6.1	3.4
												440..480Y/3/60	

DIMENSIONAL DRAWINGS

2KES-05Y .. 2FES-3Y

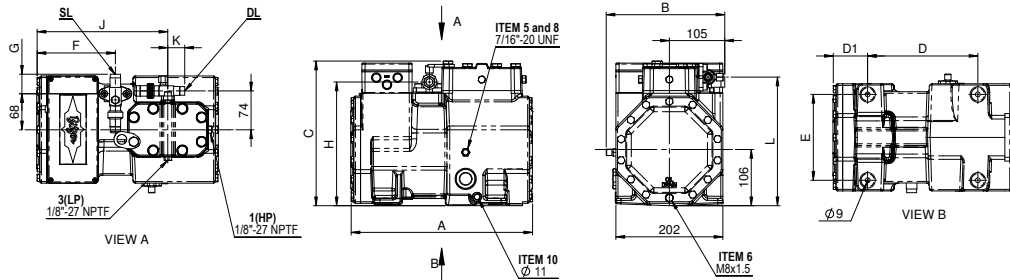

Connection positions

- 1 High pressure connection (HP)
- 2 Discharge gas temp. sensor (HP) or CIC sensor
- 3 Low pressure connection (LP)
- 4 CIC System: spray nozzle (LP)
- 5 Oil fill plug
- 6 Oil drain
- 7 Oil filter (magnetic screw)
- 8 Oil return (oil separator)
- 9a Gas equalisation (parallel operation)
- 9b Oil equalisation (parallel operation)
- 10 Crankcase heater
- 11 Oil pressure connection +
- 12 Oil pressure connection -
- 16 Connection for oil monitoring (oil sensor or differential oil pressure switch "Delta-P")
- 21 Connection for oil service valve

	A	B	C	D	D1	E	F	G	H	J	K	L
	mm	mm	mm	mm	mm	mm	mm	mm	mm	mm	mm	mm
2KES-05Y, 2JES-07Y, 2HES-1Y, 2HES-2Y	343	220	273	208	65	162	148	37	242	247	32	232
2GES-2Y, 2FES-2Y, 2FES-3Y												

BITZER COMPRESSOR COMPARISON

2EES-2Y .. 2CES-4Y



Displacement at 1450 min ⁻¹ (m ³ /h)	BITZER	BITZER Former Models	Dorin	Bock	Frascold	Copeland China	Copeland DWM
11.40	2EES-2Y	2EC-2.2	H280CC	HG22e/125-4	D2-11.1Y	-	-
	2EES-3Y	2EC-3.2		HG22e/125-4 S			
13.40	2DES-2Y	2DC-2.2	-	HG22e/160-4	D2-13.1Y	LA20-0200	DLF-201
	2DES-3Y	2DC-3.2		HG22e/160-4 S	D3-13.1Y	LA20-020E LA20-0300 LA20-030E	DLF-20X DLF-301 DLF-30X DLJ-201 DLJ-20X DLJ-301 DLJ-30X
16.20	2CES-3Y	2CC-3.2	H300CC	HG22e/190-4	D2-15.1Y	-	D2DC-500
	2CES-4Y	2CC-4.2	H350CC	HG22e/190-4 S	D3-15.1Y D3-16.1Y D4-16.1Y		D2DC-50X

TECHNICAL DATA

2EES-2Y .. 2CES-4Y



Compressor type	Motor version	Displacement at 1450 min ⁻¹ (m ³ /h)	Number of cylinders	Oil charge dm ³	Weight kg	Pipe connections				CR - Steps - % ^①	Motor connection Volt ^②	Electrical data	
						DL Discharge line		SL Suction line				Max. Operating current Amp. ^③	Max. Power consumption kW ^③
						mm	inch	mm	inch				
2EES-2Y	2	11.4	2	1.5	68	16	5/8	22	7/8		Δ / Y	10.4/6.0	3.3
2EES-3Y	1											13.4/7.5	3.8
2DES-2Y	2	13.4	2	1.5	68	16	5/8	22	7/8		220..240Δ/ 380..420Y/3/50	13.4/7.5	4.0
2DES-3Y	1											15.0/8.6	4.6
2CES-3Y	2	16.2	2	1.5	70	16	5/8	22	7/8		265..290Δ/ 440..480Y/3/60	15.8/9.1	5.0
2CES-4Y	1											17.4/10.0	5.6

DIMENSIONAL DRAWINGS

2EES-2Y .. 2CES-4Y

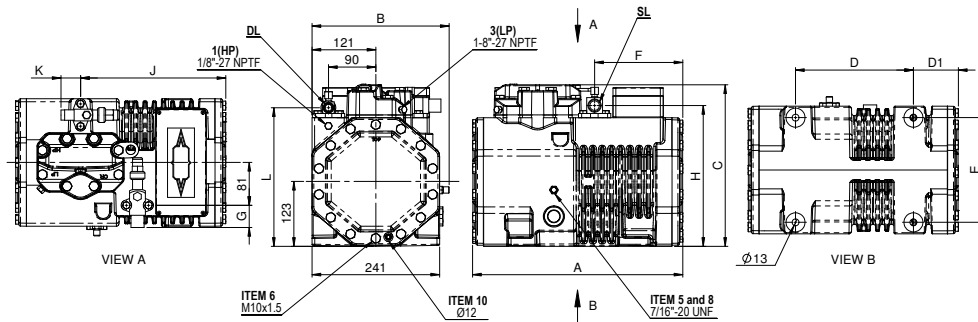

Connection positions

- 1 High pressure connection (HP)
- 2 Discharge gas temp. sensor (HP) or CIC sensor
- 3 Low pressure connection (LP)
- 4 CIC System: spray nozzle (LP)
- 5 Oil fill plug
- 6 Oil drain
- 7 Oil filter (magnetic screw)
- 8 Oil return (oil separator)
- 9a Gas equalisation (parallel operation)
- 9b Oil equalisation (parallel operation)
- 10 Crankcase heater
- 11 Oil pressure connection +
- 12 Oil pressure connection -
- 16 Connection for oil monitoring (oil sensor or differential oil pressure switch "Delta-P")
- 21 Connection for oil service valve

	A	B	C	D	D1	E	F	G	H	J	K	L
	mm	mm	mm	mm	mm	mm	mm	mm	mm	mm	mm	mm
2EES-2Y, 2EES-3Y, 2DES-2Y, 2DES-3Y	398	259	307	223	85	198	167	42	266	275	37	262
2CES-3Y, 2CES-4Y												

BITZER COMPRESSOR COMPARISON

4FES-2Y .. 4EES-6Y



Displacement at 1450 min ⁻¹ (m ³ /h)	BITZER	BITZER Former Models	Dorin	Bock	Frascold	Copeland China	Copeland DWM
18.10	4FES-3Y	4FC-3.2	H380CC	HG34e/215-4	D3-18.1Y	LA40-0300	DLL-301
	4FES-5Y	4FC-5.2	H403CC	HG34e/215-4 S	D4-18.1Y	LA40-030E	DLL-30X
					D3-19.1Y	LA40-0400	DLL-401
					D4-19.1Y	LA40-040E	DLL-40X
					Q4-20.1E		D2DD-500
					Q4-20.1Y		D2DD-50X
22.70	4EES-4Y	4EC-4.2	H503CC	HG34e/255-4	Q4-21.1Y	LA50-0400	D2SA-450 Air
	4EES-6Y	4EC-6.2	H551CC	HG34e/255-4 S	Q5-21.1Y	LA50-040E	D2SA-45X Air
					Q4-24.1E		D2SA-450
					Q4-24.1Y		D2SA-45X
					Q5-24.1Y		D2SA-550
							D2SA-55X
						DLSG-401	
						DLSG-40X	
						D2DL-400 DC	
						D2DL-40X	
						D2DL-750	
						D2DL-75X	

BITZER COMPRESSOR COMPARISON

4DES-5Y .. 4CES-9Y



Displacement at 1450 min ⁻¹ (m ³ /h)	BITZER	BITZER Former Models	Dorin	Bock	Fracold	Copeland China	Copeland DWM
26.80	4DES-5Y	4DC-5.2	H551CS	HG34e/315-4	Q4-25.1Y	2SCW-0550	D2SC-550 Air
	4DES-7Y	4DC-7.2	H701CC	HG34e/315-4 S	Q5-25.1Y Q7-25.1Y Q5-28.1E Q5-28.1Y Q7-28.1Y	2SCW-055E	D2SC-55X Air D2SC-550 D2SC-55X D2SC-650 D2SC-65X D2DB-500 DC D2DB-50X D2DB-750 D2DB-75X
32.50	4CES-6Y	4CC-6.2	H701CS	HG34e/380-4	Q5-33.1E	2SKW-0750	D2SK-650
	4CES-9Y	4CC-9.2	H751CC	HG34e/380-4 S	Q5-33.1Y Q7-33.1Y S5-33Y S7-33Y	2SKW-075E	D2SK-65X D3SA-750 D3SA-75X D3DA-500 DC D3DA-50X D3DA-750 D3DA-75X

TECHNICAL DATA

4FES-3Y .. 4CES-9Y



Compressor type	Motor version	Displacement at 1450 min ⁻¹ (m ³ /h)	Number of cylinders	Oil charge dm ³	Weight kg	Pipe connections				CR - Steps - % ^①	Motor connection Volt ^②	Electrical data	
						DL Discharge line		SL Suction line				Max. Operating current Amp. ^③	Max. Power consumption kW ^③
						mm	inch	mm	inch				
4FES-3Y	2	18.1	4	2.0	82	16	5/8	22	7/8	50	Δ / Y	16.5/9.5	5.3
4FES-5Y	1											18.8/10.8	5.8
4EES-4Y	2	22.7	4	2.0	84	16	5/8	28	1 1/8		21.2/12.2	6.9	
4EES-6Y	1										23.7/13.6	7.6	
4DES-5Y	2	26.8	4	2.0	86	22	7/8	28	1 1/8		25.2/14.5	8.1	
4DES-7Y	1										28.7/16.5	8.9	
4CES-6Y	2	32.5	4	2.0	91	22	7/8	28	1 1/8		30.8/17.7	9.7	
4CES-9Y	1										35.1/20.2	11.3	

DIMENSIONAL DRAWINGS

4FES-3Y .. 4CES-9Y

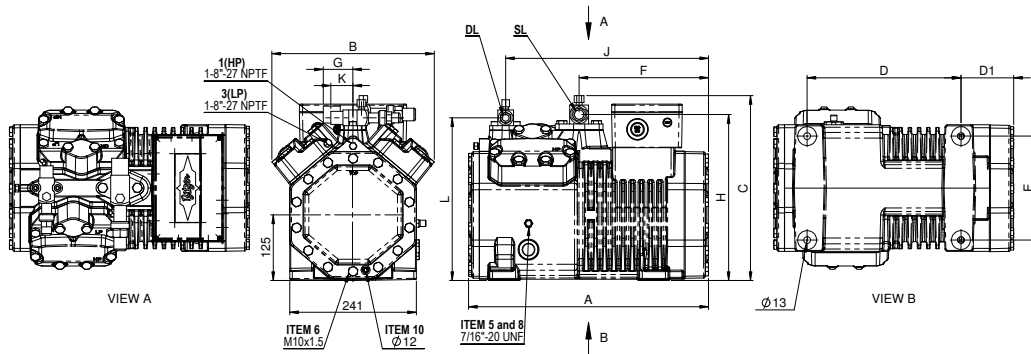

Connection positions

- 1 High pressure connection (HP)
- 2 Discharge gas temp. sensor (HP) or CIC sensor
- 3 Low pressure connection (LP)
- 4 CIC System: spray nozzle (LP)
- 5 Oil fill plug
- 6 Oil drain
- 7 Oil filter (magnetic screw)
- 8 Oil return (oil separator)
- 9a Gas equalisation (parallel operation)
- 9b Oil equalisation (parallel operation)
- 10 Crankcase heater
- 11 Oil pressure connection +
- 12 Oil pressure connection -
- 16 Connection for oil monitoring (oil sensor or differential oil pressure switch "Delta-P")
- 21 Connection for oil service valve

	A	B	C	D	D1	E	F	G	H	J	K	L
	mm	mm	mm	mm	mm	mm	mm	mm	mm	mm	mm	mm
4FES-3Y, 4FES-5Y	432	309	347	293	75	198	221	42	313	361	37	306
4EES-4Y, 4EES-6Y	432	309	352	293	75	198	221	56	316	361	37	306
4DES-5Y	432	309	352	293	75	198	221	56	316	361	42	310
4DES-7Y, 4CES-6Y, 4CES-9Y	457	309	352	293	101	198	246	56	316	386	42	310

BITZER COMPRESSOR COMPARISON

4VES-6Y .. 4TES-12Y



Displacement at 1450 min ⁻¹ (m ³ /h)	BITZER	BITZER Former Models	Dorin	Bock	Frascold	Copeland China	Copeland DWM
34.70	4VES-6Y	-	-	-	Q5-36.1Y	-	-
	4VES-7Y	4VCS-6.2			Q7-36.1Y		
	4VES-10Y	4VCS-10.2					
41.30	4TES-8Y	-	H751CS	HG4/465-4	S8-42E	3SC1-1000	D3SC-750
	4TES-9Y	4TCS-8.2	H851CS	HG4/465-4 S	S8-42Y	3SC1-100E	D3SC-75X
	4TES-12Y	4TCS-12.2	H1001CC		S12-42Y		D3SC-1000 D3SC-100X D3DC-1000 D3DC-100X D3DC-750 DC D3DC-75X

BITZER COMPRESSOR COMPARISON

4PES-10Y .. 4NES-20Y



Displacement at 1450 min ⁻¹ (m ³ /h)	BITZER	BITZER Former Models	Dorin	Bock	Frascold	Copeland China	Copeland DWM
48.50	4PES-10Y 4PES-12Y 4PES-15Y	- 4PCS-10.2 4PCS-15.2	H1001CS H1501CC	HG4/555-4 HG4/555-4 S	S10-52E S10-52Y S15-52Y	3SS1-1500 3SS1-150E	D3DS-1000 DC D3DS-100X D3DS-1500 D3DS-150X D3SS-1000 D3SS-100X D3SS-1500 D3SS-150X
56.20	4NES-12Y 4NES-14Y 4NES-20Y	- 4NCS-12.2 4NCS-20.2	H1501CS H2001CC	HG4/650-4 HG4/650-4 S	S12-56E S15-56Y S20.56Y V15-59E V15-59Y V20-59Y	4SAH-2000 4SAH-200E	D4SA-1000 D4SA-100X D4SA-2000 D4SA-200X D4SF-1000 D4SF-100X D4DA-100X D4DA-2000 D4DA-200X D4DF-1000 DC D4DF-100X

TECHNICAL DATA

4VES-6Y .. 4NES-20Y



Compressor type	Motor version	Displacement at 1450 min ⁻¹ (m ³ /h)	Number of cylinders	Oil charge dm ³	Weight kg	Pipe connections				CR - Steps - % ^①	Motor connection Volt ^②	Electrical data	
						DL Discharge line		SL Suction line				Max. Operating current Amp. ^③	Max. Power consumption kW ^③
						mm	inch	mm	inch				
4VES-6Y	3	34.7	4	2.6	129	22	7/8	28	1 1/8	50	PW ^④	9.4	6
4VES-7Y	2											16.6	11
4VES-10Y	1											19.9	12
4TES-8Y	3	41.3	4	2.6	134	28	1 1/8	35	1 3/8		380..420YY/3/50 440..480YY/3/60	11.4	7
4TES-9Y	2											19.9	13
4TES-12Y	1											25.1	14
4PES-10Y	3											12.9	8
4PES-12Y	2	48.5	4	2.6	139	28	1 1/8	35	1 3/8			22.7	14
4PES-15Y	1											28.2	16
4NES-12Y	3											14.9	9
4NES-14Y	2	56.2	4	2.6	141	28	1 1/8	35	1 3/8	26.6		17	
4NES-20Y	1									33.2		19	

DIMENSIONAL DRAWINGS

4VES-6Y .. 4NES-20Y

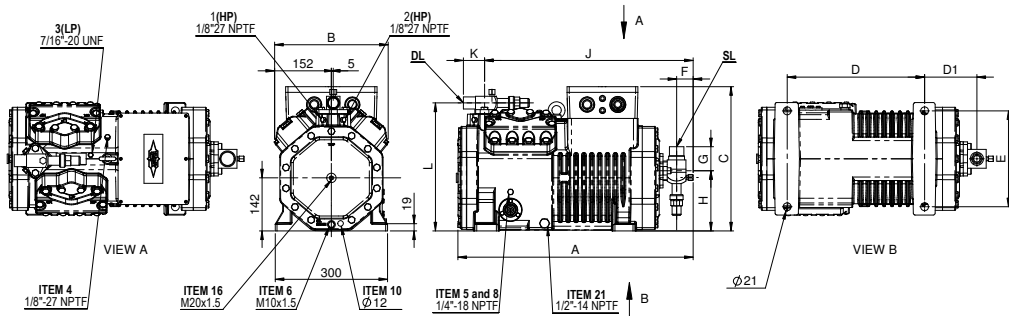

Connection positions

- 1 High pressure connection (HP)
- 2 Discharge gas temp. sensor (HP) or CIC sensor
- 3 Low pressure connection (LP)
- 4 CIC System: spray nozzle (LP)
- 5 Oil fill plug
- 6 Oil drain
- 7 Oil filter (magnetic screw)
- 8 Oil return (oil separator)
- 9a Gas equalisation (parallel operation)
- 9b Oil equalisation (parallel operation)
- 10 Crankcase heater
- 11 Oil pressure connection +
- 12 Oil pressure connection -
- 16 Connection for oil monitoring (oil sensor or differential oil pressure switch "Delta-P")
- 21 Connection for oil service valve

	A	B	C	D	D1	E	F	G	H	J	K	L
	mm	mm	mm	mm	mm	mm	mm	mm	mm	mm	mm	mm
4VES-6Y, 4VES-7Y, 4VES-10Y	633	303	385	367	140	256	44	61	161	558	42	338
4TES-8Y, 4TES-9Y, 4TES-12Y	633	303	385	367	140	256	44	64	161	557	56	342
4PES-10Y, 4PES-12Y	633	303	385	367	140	256	44	64	161	557	56	342
4PES-15Y	658	303	385	367	162	256	48	110	173	582	56	342
4NES-12Y, 4NES-14Y	633	303	385	367	140	256	44	64	161	557	56	342
4NES-20Y	658	303	385	367	162	256	48	110	173	582	56	342

BITZER COMPRESSOR COMPARISON

4JE-13Y .. 4HE-25Y



Displacement at 1450 min ⁻¹ (m ³ /h)	BITZER	BITZER Former Models	Dorin	Bock	Frascold	Copeland China	Copeland DWM
63.50	4JE-13Y	-	H1601CS	HG5/725-4	-	-	-
	4JE-15Y	4J-13.2	H2201CC	HG5/725-4 S			
	4JE-22Y	4J-22.2					
73.70	4HE-15Y	-	H2000CS	HG5/830-4	V15-71E	4SLW-1500	D4SH-1500
	4HE-18Y	4H-15.2	H2500CC	HG5/830-4 S	V15-71Y	4SLW-150E	D4SH-150X
	4HE-25Y	4H-25.2			V25-71Y	4SHH-2500	D4SH-2500
						4SHH-250E	D4SH-250X
							D4SL-1500
							D4SL-150X
							D4DH-150X
							D4DH-2500
							D4DH-250X
							D4DL-1500 DC
							D4DL-150X

BITZER COMPRESSOR COMPARISON

4GE-20Y .. 4GE-30Y



Displacement at 1450 min ⁻¹ (m ³ /h)	BITZER	BITZER Former Models	Dorin	Bock	Frascold	Copeland China	Copeland DWM
84.60	4GE-20Y	-	H2500CS	HG5/945-4	V20-84E	4STW-2000	D6SA-3000
	4GE-23Y	4G-20.2	H3000CC	HG5/945-4 S	V20-84Y	4STW-200E	D6SA-300X
	4GE-30Y	4G-30.2			V30-84Y	4SJH-3000	D6SF-2000
						4SJH-300E	D6SF-200X
							D4SJ-2000
							D4SJ-200X
							D4SJ-3000
							D4SJ-300X
							D4ST-2000
							D4ST-200X
							D4DJ-200X
							D4DJ-3000
							D4DJ-300X
							D4DT-2200 DC
							D4DT-220X

BITZER COMPRESSOR COMPARISON

4FE-25Y .. 4FE-35Y



Displacement at 1450 min ⁻¹ (m ³ /h)	BITZER	BITZER Former Models	Dorin	Bock	Frascold	Copeland China	Copeland DWM
101.80	4FE-25Y 4FE-28Y 4FE-35Y	-	-	-	V25-103E V25-103Y V35-103Y Z25-106E Z25-106Y Z35-106Y	6SLW-2500 6SLW-250E 6SHH-3500 6SHH-350E	D6SH-2000 D6SH-200X D6SH-3500 D6SH-350X D6SL-2500 D6SL-250X D6DH-200X D6DH-3500 D6DH-350X D6DL-2700 DC D6DL-270X

TECHNICAL DATA

4JE-13Y .. 4FE-35Y



Compressor type	Motor version	Displacement at 1450 min ⁻¹ (m ³ /h)	Number of cylinders	Oil charge dm ³	Weight kg	Pipe connections				CR - Steps - % ^①	Motor connection Volt ^②	Electrical data					
						DL Discharge line mm	DL Discharge line inch	SL Suction line mm	SL Suction line inch			Max. Operating current Amp. ^③	Max. Power consumption kW ^③				
4JE-13Y	3	63.5	4	4.0	179	28	1 1/8	42	1 5/8	50	380..420YY/3/50 440..480YY/3/60	18.8	11				
4JE-15Y	2				190							30.8	19				
4JE-22Y	1				190							37.2	21				
4HE-15Y	3	73.7	4	4.0	183	28	1 1/8	42	1 5/8			50	380..420YY/3/50 440..480YY/3/60	21.4	13		
4HE-18Y	2				190									36.7	22		
4HE-25Y	1				194									44	25		
4GE-20Y	3	84.6	4	4.5	192	28	1 1/8	54	2 1/8					50	380..420YY/3/50 440..480YY/3/60	24.6	16
4GE-23Y	2				192											43.9	27
4GE-30Y	1				206											51.2	28
4FE-25Y	3	101.8	4	4.5	196	28	1 1/8	54	2 1/8							50	380..420YY/3/50 440..480YY/3/60
4FE-28Y	2				207					52.8	31						
4FE-35Y	1				207					62.1	35						

DIMENSIONAL DRAWINGS

4JE-13Y .. 4FE-35Y

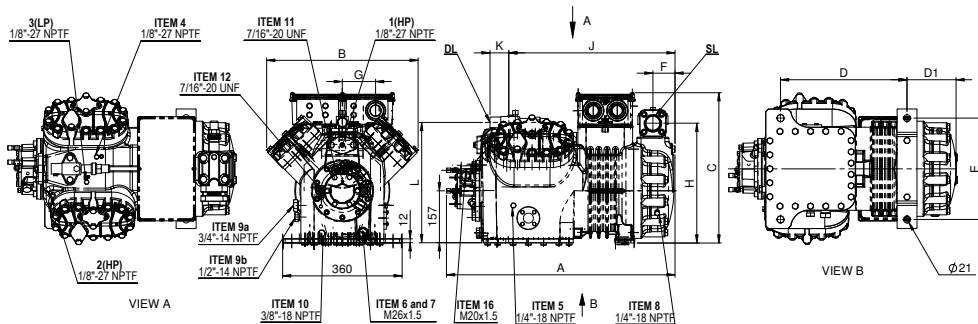

Connection positions

- 1 High pressure connection (HP)
- 2 Discharge gas temp. sensor (HP) or CIC sensor
- 3 Low pressure connection (LP)
- 4 CIC System: spray nozzle (LP)
- 5 Oil fill plug
- 6 Oil drain
- 7 Oil filter (magnetic screw)
- 8 Oil return (oil separator)
- 9a Gas equalisation (parallel operation)
- 9b Oil equalisation (parallel operation)
- 10 Crankcase heater
- 11 Oil pressure connection +
- 12 Oil pressure connection -
- 16 Connection for oil monitoring (oil sensor or differential oil pressure switch "Delta-P")
- 21 Connection for oil service valve

DIMENSIONAL DRAWINGS

4JE-13Y .. 4FE-35Y



	A	B	C	D	D1	E	F	G	H	J	K	L
	mm	mm	mm	mm	mm	mm	mm	mm	mm	mm	mm	mm
4JE-13Y, 4JE-15Y	688	456	452	381	151	305	66	110	361	501	56	362
4JE-22Y	688	456	452	381	151	305	66	110	361	501	56	362
4HE-15Y, 4HE-18Y	688	456	452	381	151	305	66	110	361	501	56	362
4HE-25Y	737	456	452	381	200	305	87	127	377	549	56	362
4GE-20Y, 4GE-23Y	706	456	452	381	169	305	76	127	377	519	56	362
4GE-30Y	737	456	452	381	200	305	87	127	377	549	56	362
4FE-25Y, 4FE-28Y	737	456	452	381	200	305	87	127	377	549	56	362
4FE-35Y	737	456	452	381	200	305	87	127	377	549	56	362

BITZER COMPRESSOR COMPARISON

6JE-22Y .. 6GE-40Y



Displacement at 1450 min ⁻¹ (m ³ /h)	BITZER	BITZER Former Models	Dorin	Bock	Frascold	Copeland China	Copeland DWM
95.30	6JE-22Y	-	-	HG6/1080-4	V25-93Y	-	-
	6JE-25Y	6J-22.2		HG6/1080-4 S	V32-93Y		
	6JE-33Y	6J-33.2					
110.50	6HE-25Y	-	H3000CS	HG6/1240-4	-	-	-
	6HE-28Y	6H-25.2	H3500CC	HG6/1240-4 S			
	6HE-35Y	6H-35.2					
126.80	6GE-30Y	-i	H3500CS	HG6/1410-4	Z30-126E	6STW-3200	D6SJ-3000
	6GE-34Y	6G-30.2	H4000CC	HG6/1410-4 S	Z30-126Y	6STW-320E	D6SJ-300X
	6GE-40Y	6G-40.2			Z40-126Y	6SJH-4000 6SJH-400E	D6SJ-4000 D6SJ-400X D6ST-3200 D6ST-320X D6DJ-300X D6DJ-4000 D6DJ-400X D6DT-3200 DC D6DT-300X

TECHNICAL DATA

6JE-22Y .. 6GE-40Y



Compressor type	Motor version	Displacement at 1450 min ⁻¹ (m ³ /h)	Number of cylinders	Oil charge dm ³	Weight kg	Pipe connections				CR - Steps - % ^①	Motor connection Volt ^②	Electrical data	
						DL Discharge line		SL Suction line				Max. Operating current Amp. ^③	Max. Power consumption kW ^③
						mm	inch	mm	inch				
6JE-22Y	3				213						26.6	16	
6JE-25Y	2	95.3	6	4.75	228	35	1%	54	2 1/8		46.4	27	
6JE-33Y	1				231						53.2	30	
6HE-25Y	3				224					380..420YY/3/50	31.3	19	
6HE-28Y	2	110.5	6	4.75	228	35	1%	54	2 1/8	66	53.2	33	
6HE-35Y	1				235					altern. 440..480YY/3/60	64.4	36	
6GE-30Y	3				228					33	38	23	
6GE-34Y	2	126.8	6	4.75	228	35	1%	54	2 1/8	PW^④	65.5	40	
6GE-40Y	1				238						73.9	42	

DIMENSIONAL DRAWINGS

6JE-22Y .. 6GE-40Y

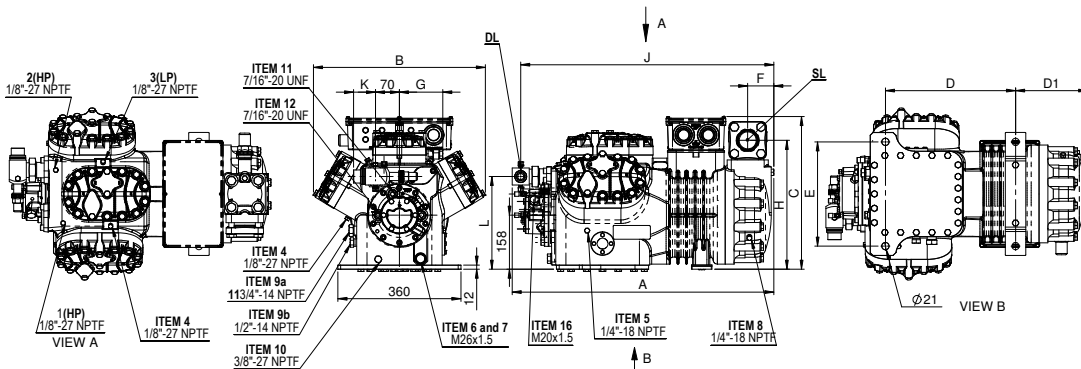

Connection positions

- 1 High pressure connection (HP)
- 2 Discharge gas temp. sensor (HP) or CIC sensor
- 3 Low pressure connection (LP)
- 4 CIC System: spray nozzle (LP)
- 5 Oil fill plug
- 6 Oil drain
- 7 Oil filter (magnetic screw)
- 8 Oil return (oil separator)
- 9a Gas equalisation (parallel operation)
- 9b Gas equalisation (parallel operation)
- 10 Crankcase heater
- 11 Oil pressure connection +
- 12 Oil pressure connection -
- 16 Connection for oil monitoring (oil sensor or differential oil pressure switch "Delta-P")
- 21 Connection for oil service valve

DIMENSIONAL DRAWINGS

6JE-22Y .. 6GE-40Y



	A	B	C	D	D1	E	F	G	H	J	K	L
	mm	mm	mm	mm	mm	mm	mm	mm	mm	mm	mm	mm
6JE-22Y, 6JE-25Y	766	503	447	381	211	305	76	127	377	740	64	271
6JE-33Y	797	503	447	381	242	305	87	127	377	771	64	271
6HE-25Y, 6HE-28Y	766	503	447	381	211	305	76	127	377	740	64	271
6HE-35Y	797	503	447	381	242	305	87	127	377	771	64	271
6GE-30Y, 6GE-34Y	766	503	447	381	211	305	76	127	377	740	64	271
6GE-40Y	797	503	447	381	242	305	87	127	377	771	64	271

BITZER COMPRESSOR COMPARISON

6FE-40Y .. 6FE-50Y



Displacement at 1450 min ⁻¹ (m ³ /h)	BITZER	BITZER Former Models	Dorin	Bock	Frascold	Copeland China	Copeland DWM
151.60	6FE-40Y	-	H4500CS	HG7/1620-4	W40-142Y	6SUW-4000	D8DH-400X
	6FE-44Y	6F-40.2	H5000CC	HG7/1620-4 S	Z40-154E	6SUW-400E	D8DH-5000
	6FE-50Y	6F-50.2		HG7/1860-4 HG7/1860-4 S	Z40-154Y Z50-154Y	6SKH-5000 6SKH-500E	D8DH-500X D8DL-370X D8SH-400X D6SU-400X D6SK-400X D6SK-5000 D6SK-500X

TECHNICAL DATA

6FE-40Y .. 6FE-50Y



Compressor type	Motor version	Displacement at 1450 min ⁻¹ (m ³ /h)	Number of cylinders	Oil charge dm ³	Weight kg	Pipe connections				CR - Steps - % ^①	Motor connection Volt ^②	Electrical data		
						DL Discharge line		SL Suction line				Max. Operating current Amp. ^③	Max. Power consumption kW ^③	
						mm	inch	mm	inch					
6FE-40Y	3	151.6	6	4.75	238	42	1 ⁵ / ₈	54	2 ¹ / ₈	66 altern. 33	380..420YY/3/50	48.5	27	
6FE-44Y	2				241						440..480YY/3/60		83.2	46
6FE-50Y	1				241						440..460YY/3/60		96.2	51

DIMENSIONAL DRAWINGS

6FE-40Y .. 6FE-50Y

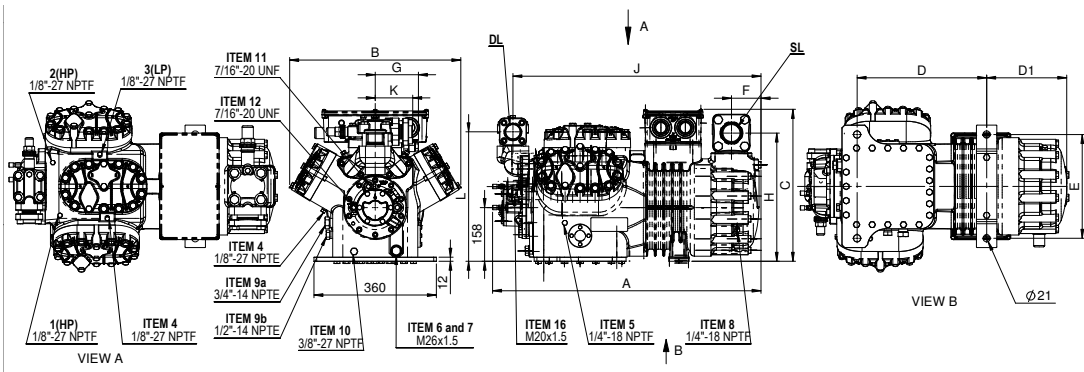

Connection positions

- 1 High pressure connection (HP)
- 2 Discharge gas temp. sensor (HP) or CIC sensor
- 3 Low pressure connection (LP)
- 4 CIC System: spray nozzle (LP)
- 5 Oil fill plug
- 6 Oil drain
- 7 Oil filter (magnetic screw)
- 8 Oil return (oil separator)
- 9a Gas equalisation (parallel operation)
- 9b Oil equalisation (parallel operation)
- 10 Crankcase heater
- 11 Oil pressure connection +
- 12 Oil pressure connection -
- 16 Connection for oil monitoring (oil sensor or differential oil pressure switch "Delta-P")
- 21 Connection for oil service valve

	A	B	C	D	D1	E	F	G	H	J	K	L
	mm	mm	mm	mm	mm	mm	mm	mm	mm	mm	mm	mm
6FE-40Y, 6FE-44Y	790	503	447	381	242	305	87	127	377	729	111	381
6FE-50Y	790	503	447	381	242	305	87	127	377	729	111	381

BITZER COMPRESSOR COMPARISON

8GE-60Y .. 8FE-70Y



Displacement at 1450 min ⁻¹ (m ³ /h)	BITZER	BITZER Former Models	Dorin	Bock	Frascold	Copeland China	Copeland DWM
185.00	8GE-60Y	8CG-60.2	H6000CC	HG7/2110-4 HG7/2110-4 S	W40-168Y W50-168Y W50-187Y W60-187Y	-	D8SJ-4500 D8SJ-450X D8SJ-500X D8SJ-6000 D8SJ-600X D8DJ-500X D8DJ-6000 D8DJ-600X D8DT-450X
221.00	8FE-70Y	8FC-70.2	-	HG8/2470-4 HG8/2470-4 S HG8/2830-4 HG8/2830-4 S	W60-206Y W70-206Y W70-228Y W75-228Y W75-240Y W80-240Y	-	D8SK-600X D8SK-7000 D8SK-700X

TECHNICAL DATA

8GE-60Y .. 8FE-70Y



Compressor type	Motor version	Displacement at 1450 min ⁻¹ (m ³ /h)	Number of cylinders	Oil charge dm ³	Weight kg	Pipe connections				CR - Steps - % ^①	Motor connection Volt ^②	Electrical data	
						DL Discharge line		SL Suction line				Max. Operating current Amp. ^③	Max. Power consumption kW ^③
						mm	inch	mm	inch				
8GE-60(Y)	1	185	8	5.0	350	42	1½	76	3⅜	75 altern.	PW ^④ 380..420ΔΔY/3/50	113	63
8FE-70(Y)	1	221	8	5.0	374	54	2½	76	3⅜	50	440..480ΔΔY/3/60	139	78

DIMENSIONAL DRAWINGS

8GE-60Y .. 8FE-70Y

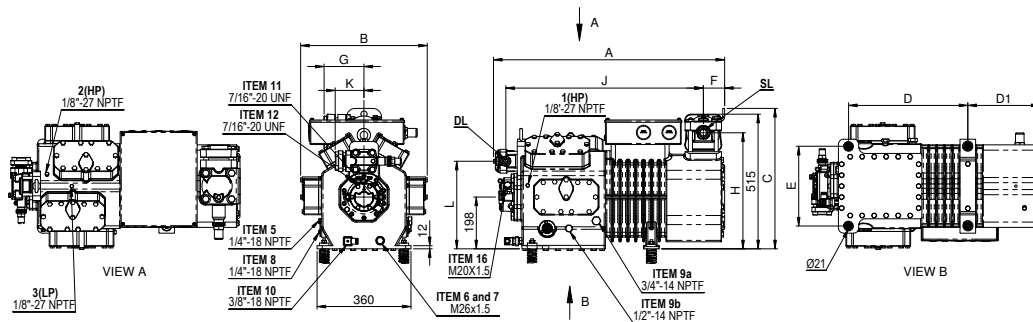

Connection positions

- 1 High pressure connection (HP)
- 2 Discharge gas temp. sensor (HP) or CIC sensor
- 3 Low pressure connection (LP)
- 4 CIC System: spray nozzle (LP)
- 5 Oil fill plug
- 6 Oil drain
- 7 Oil filter (magnetic screw)
- 8 Oil return (oil separator)
- 9a Gas equalisation (parallel operation)
- 9b Oil equalisation (parallel operation)
- 10 Crankcase heater
- 11 Oil pressure connection +
- 12 Oil pressure connection -
- 16 Connection for oil monitoring (oil sensor or differential oil pressure switch "Delta-P")
- 21 Connection for oil service valve

	A	B	C	D	D1	E	F	G	H	J	K	L
	mm	mm	mm	mm	mm	mm	mm	mm	mm	mm	mm	mm
8GE-60Y	886	485	538	457	281	305	82	158	445	757	110	336
8FE-70Y	902	485	538	457	281	305	82	158	444	764	129	336

- ① CR Capacity control (option)
220..240 V/1/50/60 Hz
- ② Tolerance ($\pm 10\%$) based on mean value of voltage range. Other voltages and electrical supplies upon request.
- ③ Data refer to 400 V/3/50 Hz at direct mains operation. For the selection of contactors, cables and fuses the max. operating current / max. power consumption must be considered. See also ⑤ Contractors: Operational category AC3. Use thermal overload relay to limit max operating current.
- ④ PW: motor for Part Winding start Y/YY
 - 4VES-6Y .. 6FE-50Y winding partition 50%/50%
 - 8GE-50Y .. 8FE-70Y $\Delta/\Delta\Delta$ winding partition 60%/40%
 - For Part Winding start select motor contactors for approx. 60% of the max. operating current. Y/ Δ version upon request
- ⑤ Data for frequency inverter (FI) selection
 - motor version 3 (R134a compressors):
based on 400 V/3/50 Hz supply voltage and use of 400 V/3/50 Hz standard motor for FI operation up to 70 Hz.
 - FI with motor version 1 and 2:
operation in the entire application range above 50 Hz requires motor with special voltage.
Selection upon request.

NOTES



A large grid of small green dots is arranged across the page, intended for taking notes. The grid consists of 20 columns and 20 rows of dots.



BITZER Australia Pty Limited
Head Office

134 Dunheved Circuit,
St Marys, NSW 2760
Australia

tel +61 (2) 8801 9300

fax +61 (2) 9673 4698

info@bitzer.com.au

www.bitzeravp.com.au

www.bitzer.com.au